

Fan The Future Lead The Way

CONINCO Fans is a leading supplier of high-efficiency, large-scale fans, specializing in providing high-quality HVLS (High Volume Low Speed) fan solutions for various industrial and commercial environments.

Our products are designed to improve air quality and temperature control in workspaces through energy-saving, eco-friendly, and comfortable air circulation. They are widely used in large spaces such as warehouses, production workshops, shopping malls, restaurants, stations, sports venues, and logistics centers.

CONINCO HVLS fans feature advanced technological designs, combined with intelligent control systems and efficient power transmission systems, enabling high airflow with low power consumption. This ensures comprehensive air circulation, significantly enhancing temperature uniformity within spaces while greatly reducing energy consumption.

We are committed to offering customized solutions to meet the unique needs of different clients and have established a strong global service network to ensure the sustained and stable operation of our products, delivering long-term energy-saving benefits.

As an industry leader, CONINCO Fans not only values product quality and innovation but also places a strong emphasis on after-sales service and technical support, striving to provide each client with a professional and reliable service experience.

Our mission is to help customers achieve **"Powering Comfort, Elevating Performance"** while enhancing the overall experience of their spaces through innovative technology and efficient products.

Whether for new construction projects or renovation works, CONINCO will be your best choice.

CONINCO Technology (Singapore) Pte. Ltd.

Email: support@conincofans.com
Website: www.conincofans.com
Tel: +65 69587868

All rights reserved. | Specifications subject to change without notice.



LuxAir Series Fans

Operating Instructions

2025.01

CONINCO

Installation Checklist



Please complete the following checklist before powering on the fan. Do not operate the fan if any item is incomplete. Contact an authorized CONINCO technician for assistance if needed.

A. Pre-Installation

- Check packaging for any signs of damage during transportation
- Verify all parts and components match the packing list
- Confirm the installation structure meets load-bearing requirements
- Ensure personnel are qualified and equipped with proper PPE

B. Mounting & Structure

- Mounting bracket is securely installed using proper bolts and fasteners
- All connections are tightened with a torque wrench as per specifications
- Downrod is installed vertically, fan aligned with center axis
- Installation height meets clearance requirements (at least 2.5m from floor)
- Anti-vibration washers and lock nuts are in place to prevent loosening

C. Electrical

- Cables used are compliant and protected with insulation sleeves
- Power connections are correct and grounding is secure
- Communication cables between control box and fan are properly connected
- Use multimeter to check voltage and resistance before powering on
- All electrical work complies with local electrical codes (e.g. NEC/IEC)

D. Blades & Hub

- Blades are installed in correct order and orientation
- Blade-to-hub bolts are tightened and torque is recorded
- Blade spacing is even, no risk of interference
- Anti-loosening devices and safety wires are installed properly

E. Final Inspection

- All fasteners are double-checked and secure
- Adequate clearance from all surroundings (side and top)
- Initial power-on test of control system is successful
- Fan rotates in correct direction (clockwise or counterclockwise)
- Fan runs smoothly with no abnormal noise or vibration

F. Handover

- Demonstrate controller functions including start/stop/speed control
- Provide user manual and warranty card to customer
- Complete installation log and obtain customer signature

Note: This checklist must be signed by the installation supervisor and documented with photos before operation.

Correct Use and Application



This Operation Manual applies to CONINCO HVLS Industrial Fans (hereinafter referred to as "the product"). The product is specifically designed to provide ventilation and cooling in large spaces such as industrial facilities, warehouses, logistics centers, manufacturing plants, and commercial venues. Please read this manual carefully before installing, operating, or maintaining the product, and keep it for future reference.

Proper Use

This product is intended solely for the purpose of improving air circulation and temperature regulation as described in this manual. Any use beyond the scope of this manual, including operation in flammable, explosive, highly corrosive, or extremely dusty environments, shall be deemed improper and may result in personal injury, equipment damage, or property loss.

Definition of User Responsibility

In this manual, the "user" refers to the individual or legal entity that operates the product, including its employees or designated representatives. In special cases such as leasing or subcontracting, the user is defined as the party responsible for operation and maintenance of the fan under contractual agreement.

The User Must Ensure:

- The fan is used solely for its intended purpose;
- No overloading or improper usage occurs;
- No structural or functional modifications are made without authorization;
- All applicable national and local electrical and construction codes are strictly followed;
- Installation, operation, and maintenance are carried out according to this manual and the Installation Guide;
- All operators have read, understood, and received adequate training on this manual.

Failure to comply with this manual will void the product warranty.

CONINCO reserves the right to deny warranty claims if the product is improperly installed, wired, operated, or serviced by the user or any third party without prior authorization from CONINCO.

Additional Equipment and Modifications

Any installation of accessories or functional upgrades that may affect the fan's performance must be approved in writing by CONINCO. In some regions, local authority approval may also be required. However, such approval does not constitute authorization from CONINCO.

Contents

Preface.....	04
Product Description.....	05
Technical Specifications.....	06
Fan Diagram.....	07
Installation Conditions and Types.....	08
Packing.....	10
Installation Tool Requirements.....	11
Parts List.....	12
Fan Installation Guidelines.....	16
Error Code Description.....	26
Safety Instructions.....	27
Troubleshooting.....	28
Application Environment.....	29
Warranty & Maintenance.....	30
Control Cabinet User Manual.....	32

Preface

Thank you for choosing CONINCO HVLS Fans. This manual is designed to help you understand the safe and effective use of your fan system. It contains essential information regarding installation, operation, maintenance, and safety guidelines to ensure optimal performance and longevity of your fan.

CONINCO is committed to providing high-quality, innovative ventilation solutions for industrial and commercial spaces. Our HVLS (High Volume, Low Speed) fans are engineered for superior efficiency, energy savings, and environmental comfort. Please read this manual thoroughly before installing or operating the fan. Proper understanding and adherence to the instructions will help you maximize the performance and safety of the product.

Should you have any questions or need assistance, please visit our website at www.conincofans.com or contact our customer service team.

We appreciate your trust in CONINCO and wish you a comfortable and productive environment with our fan systems.

Product Description

LuxAir series HVLS (High-Volume Low-Speed) fans are high-performance products specifically designed to optimize air circulation in large spaces, enhance comfort, and improve energy efficiency. Their innovative airflow design provides gentle yet efficient air coverage, helping to significantly improve the environment, reduce energy consumption, and making them especially suitable for places that require temperature stability and air quality control.

By choosing LuxAir products, customers gain a sustainable, cost-effective, and high-performance solution for airflow and comfort needs.

Application Scenarios:

- **Commercial Spaces:** Large shopping malls, supermarkets, exhibition halls, used to enhance air circulation and optimize customer experience.
- **Public Facilities:** Sports venues, airport terminals, schools, and other spacious areas, used to maintain fresh air and temperature balance.
- **Agriculture and Animal Husbandry:** Agricultural greenhouses, farms, used to improve air quality and reduce mold and pest problems.
- **Fitness and Leisure:** Gyms, yoga studios, and other indoor sports spaces, used to provide a cool and comfortable exercise environment.
- **Industrial Sites:** Factories, logistics warehouses, used for expelling heat, controlling humidity, and improving worker comfort.

LuxAir series fans offer excellent airflow coverage, low energy consumption, quiet and efficient operation, and intelligent control, providing a comprehensive air optimization solution for industrial, commercial, and public spaces. It is one of the top-performing HVLS fan products available in the market today.



Technical Specifications

Fan	Diameter	Air volume,m ³ /min	Weight	Max speed	Input power	Full load current
LA6-42	14ft (4.2m)	7550	115 lb (52kg)	72RPM	0.35kw	1.5A
LA6-36	12ft (3.6m)	6560	106 lb (48kg)	95RPM	0.33kw	1.3A
LA6-30	10ft (3.0m)	5250	97 lb (44kg)	110RPM	0.30kw	1.1A
LA6-25	8ft (2.5m)	4550	90 lb (41kg)	130RPM	0.26kw	0.8A
LA6-20	6.5ft (2.0m)	3900	84 lb (38kg)	150RPM	0.14kw	0.4A

Installation Requirements:

- Building Structure: H-beams, I-beams, steel-concrete square beams, spherical column types, and other structures.
- The minimum safe distance between the fan blades and obstacles is 200mm.

Others:

- Weight: Above weight does not include control cabinet, extension rods, top connection components, etc.
- Fan Diameter: The diameters listed above are standard product sizes; other specifications can be customized.
- Blade Color: The standard color is black, other colors are customizable.
- Input Power: Single-phase 220V \pm 10%.
- Alternative Voltage Specifications Available Upon Request

Fan Diagram

Contact CONINCO if you are missing any parts or hardware needed for installation.

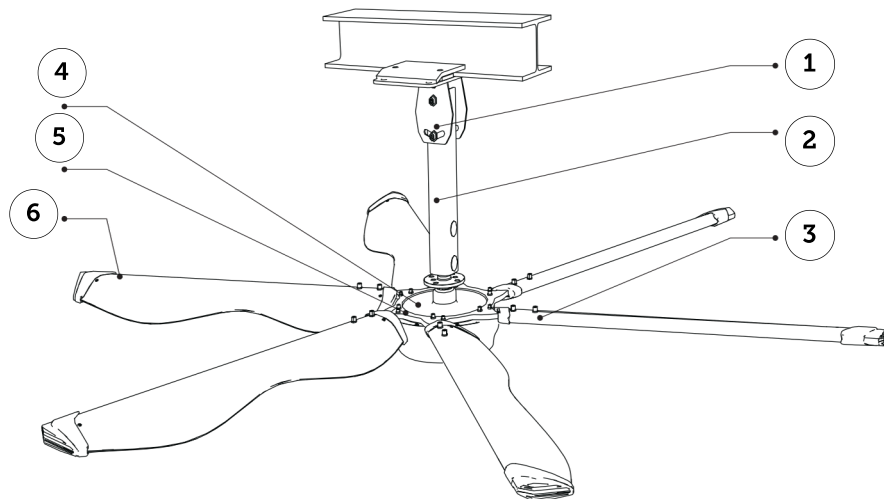

- 1** Top plate

2 Extension tube

3 Fan blade
- 4** PMSM motor

5 Integrated fan blade connector

6 Winglet

Installation Conditions and Types

Roof installation requirement

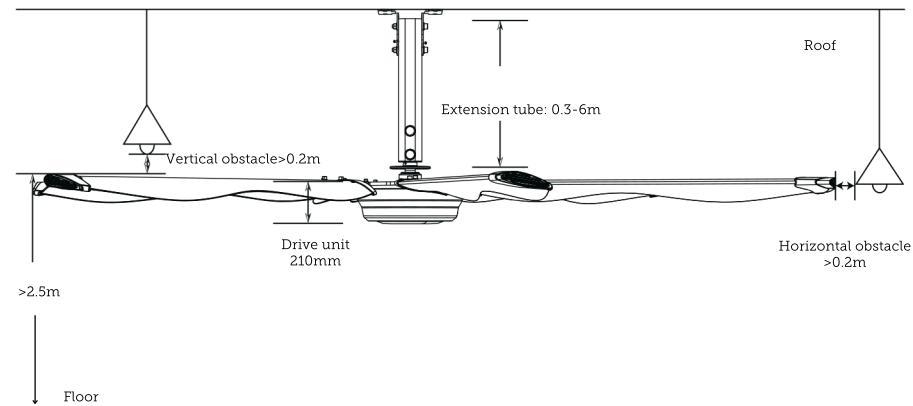

01 I-Beam Installation

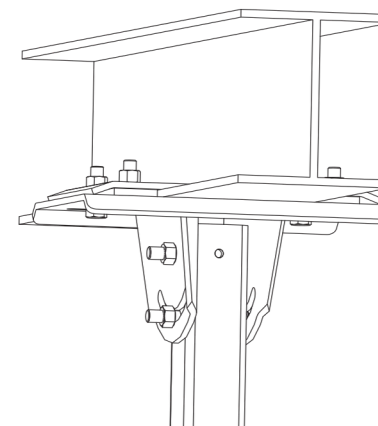

Brief Installation Guide:

Pre-assemble the top plate, shim plate, and clamping plate. Install the assembly symmetrically on both sides of the top plate. Ensure that the long side of the top plate is oriented perpendicular to the long axis of the I-beam. The shim plate should be positioned flush against the I-beam, and the clamping plate must be securely fastened to ensure a tight fit against the beam.

Installation Conditions and Types

02 Concrete Structure Installation

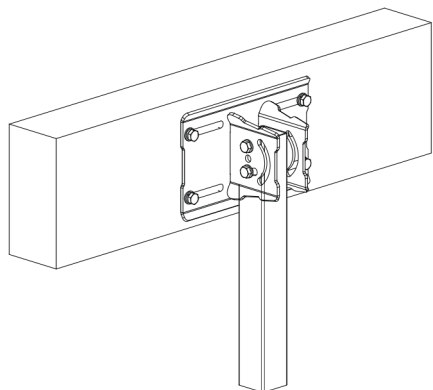

Brief Installation Guide:

Select the appropriate top plate according to the dimensions of the target I-beam. Position the top plate along the side of the beam and use a marker to accurately indicate the drilling points. Using a rotary hammer or impact drill, drill holes at the marked locations – the drilling depth should correspond to the length of the anchor bolts to be used. Once the holes are prepared, secure the top plate firmly in place using the anchor bolts.

03 Truss/Frame Structure Installation

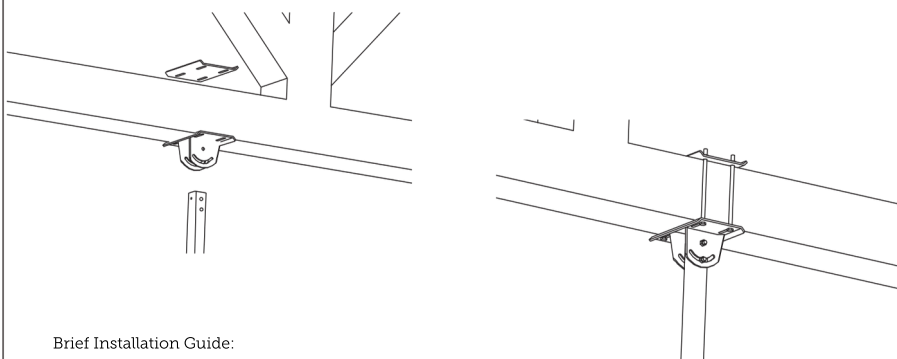

Brief Installation Guide:

Position the upper plate on top of the beam and the top plate beneath the beam. Align both plates accurately and secure them using four pairs of long bolts. Tighten two nuts on each end of every bolt to ensure a firm and stable connection between the plates and the beam structure.

Packing

Please check that all components are present in the fan packaging before beginning installation. If you have ordered multiple fans, make sure to keep the components for each fan separate. The components are rated differently for each fan and are not interchangeable.

Note: Illustrations are not to scale.
(For example, in the case of an I-beam structural configuration)









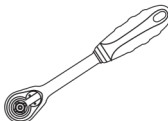

Packing List
Packing specification *Taking 3.0 m Luxair fan as an example

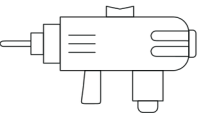
No.	Dimension (L*W*H mm)	Volume (m3)	Gross weight (kg)	Remark
1	1400*620*340	0.29	75	Carton

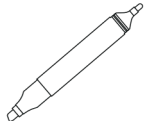

No.	Item	No.	Item
1	PMSM Motor	5	Turnbuckle
2	Integrated fan blade connector	6	Motor protective cover
3	Coil of wire	7	Fan blades
4	Control cabinet	8	Extension tube
5	L-shaped top plate	9	
6	Screw and fastener kits	10	

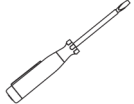

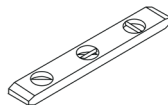

Installation Tool Requirements

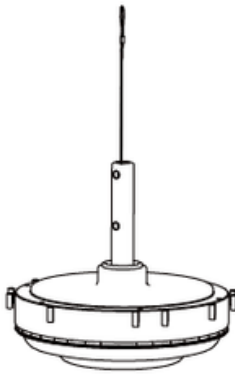
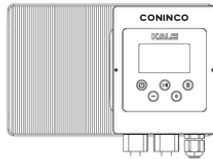
No.	Part	Diagram	No.	Part	Diagram
1	5mm/6mm Allen wrench		8	Quick Wrench	
2	Wire-cutter		9	Impact Drill	
3	Stripper		10	Paintbrush	
4	16mm Open End Wrench		11	Tape Measure	
5	24mm Open End Wrench		12	Screw glue	
6	Straight Screwdriver		13	Diastimeter	
7	Cross Screwdriver		14	Level Ruler	



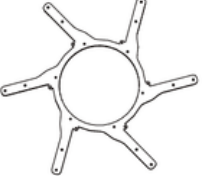
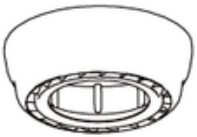
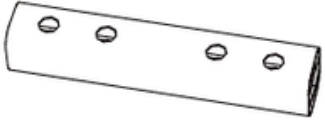

Parts List

No.	Part	Qty.	Diagram	Remarks
1	Motor	1		Main component
2	Controller	1		Main component
3	Fan Blade	6		Main component
4	Top Plate	1		Mounting Component

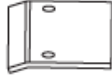

Parts List

No.	Part	Qty.	Diagram	Remarks
5	LOGO Cover	1		Mounting Component
6	Steel Wire Plate	1		Mounting Component
7	Integrated Fan Blade Connector	6		Safety Component
8	Motor Protective Cover	1		Securing component or mechanical locking component
9	Extension Tube	1-2		Mounting Component









Parts List

No.	Part	Qty.	Diagram	Remarks
10	Extension Tube Connecting Shaft	1		Mounting Component
11	Clamp Plate	2		Mounting Component
12	Shim Plate	2		Safety Component
13	U-shaped lock buckle	39		Securing component or mechanical locking component
14	Turnbuckle	4		Use of wiring

Parts List

No.	Part	Qty.	Diagram	Remarks
15	Steel Wire Rope	40m		Safety Component
16	Cable	10m+40m		
17	Metal Hose	2		

Fastener packing list

No.	M8*20 screws	No.	M6*20 screws	No.	Drywall nails
1		2		3	
No.	M10*100 screw	No.	M5*20 screw	No.	M10*30 screw
4		5		6	
No.	M15*65 screw	No.	Buckle on beam	No.	User Guide
7		8		9	

Fan Installation Guidelines

Step 1 Installation Readiness Check

Check the product and accessories to make sure it is correct. Prepare safety measures (such as seat belts, safety helmets, etc.), climbing equipment, tools, etc.

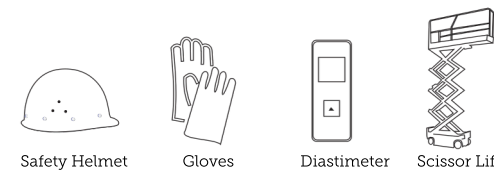

Step 2 Install the Integrated Fan Blade Connector

- 2.1 Use a 5mm Allen wrench to install 6 M6 * 20 screws.
- 2.2 Use a 4mm Allen wrench to install 6 M5 * 20 screws to install the motor protective cover.

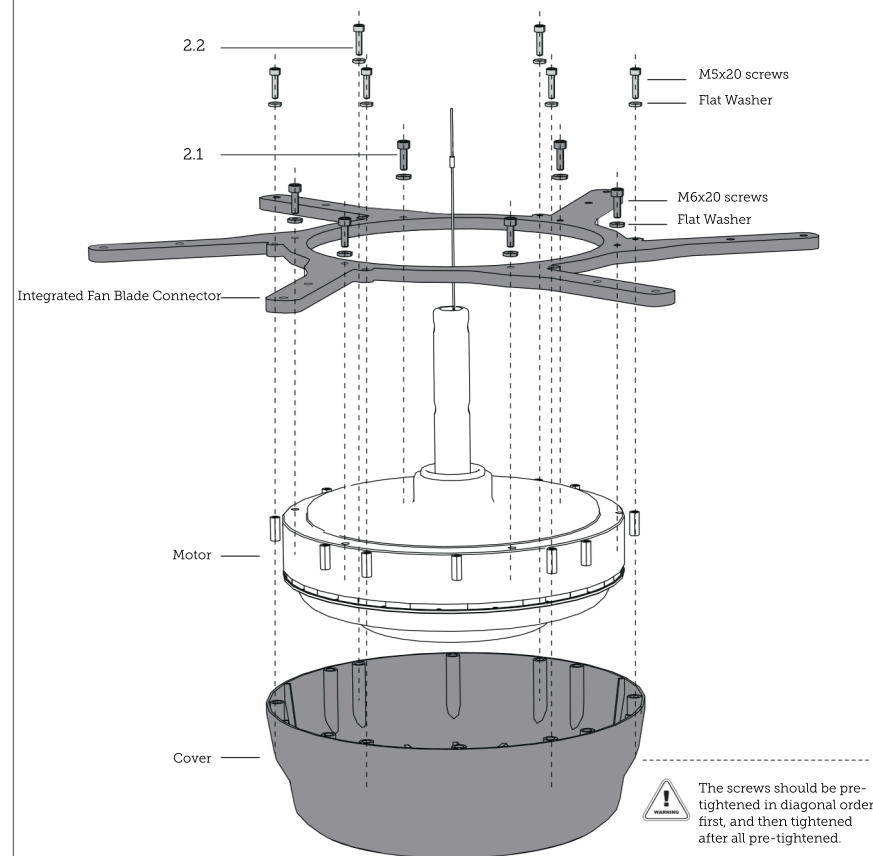

Fan Installation Guidelines

Step 3 Install the steel wire plate

Put the steel wire plate on the motor, do not tighten the screws on the steel wire plate, it is easy to adjust the angle of the wire rope.

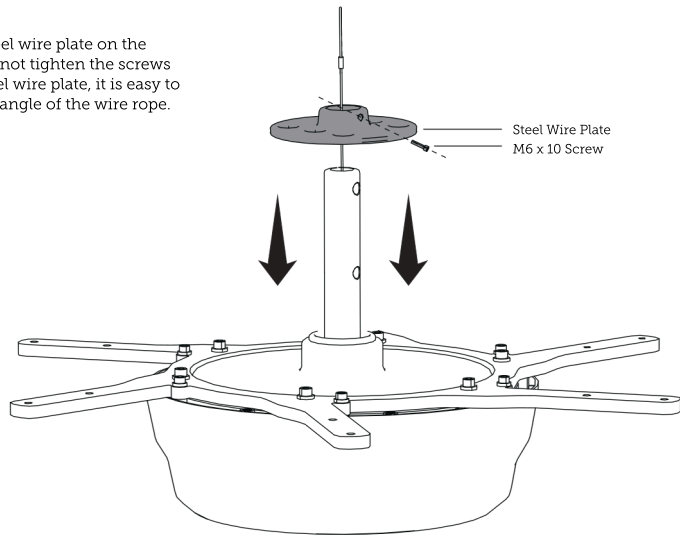

Step 4 Install the Top Plate

4.1 Before installing the top plate, place the shim plate and clamp plate on the top plate in sequence on the ground. 4.2 Pre-tighten the M16*65mm screws with 24mm wrench and 24mm sleeve to ensure it does not loosen or fall off, and leave a certain gap to facilitate the installer to clamp the top plate on the I-beam. Fully attach the top plate to the I-beam, make sure the top plate is vertical to the I-beam, pre-tighten the top plate screws to prevent falling, and tighten the screws last.

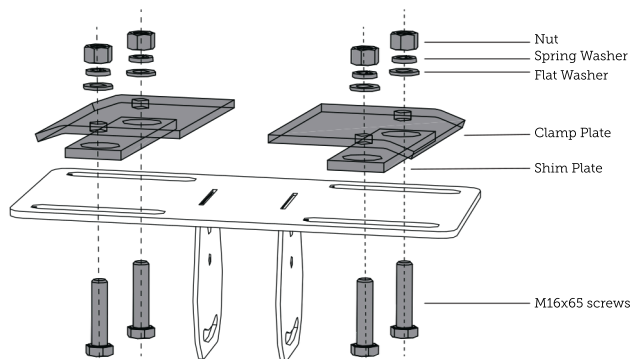

Before installing the top plate, you need to measure the width of the I-beam to see if it is horizontal, and choose the right top plate specifications and accessories.

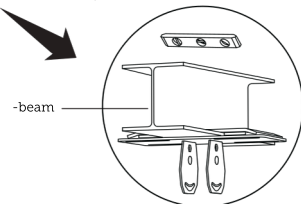

Fan Installation Guidelines

Step 5 Install the Extension Tube

Put the extension tube in the top plate connector, align the holes, fix the extension tube to the top plate with M10X100mm screws, adjust the verticality with a level, pre-tighten the screws with a 16mm sleeve and a wrench, and finally tighten them with a quick wrench.

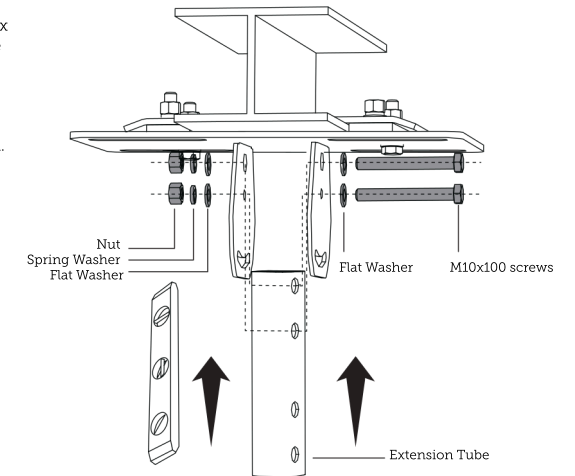

Step 6 Threading the Cable Wires

6.1 Installing buckle on beam.
6.2 Extension tube through cable, cable from the extension tube above the entrance into the extension tube, cable through the extension tube about 50cm.

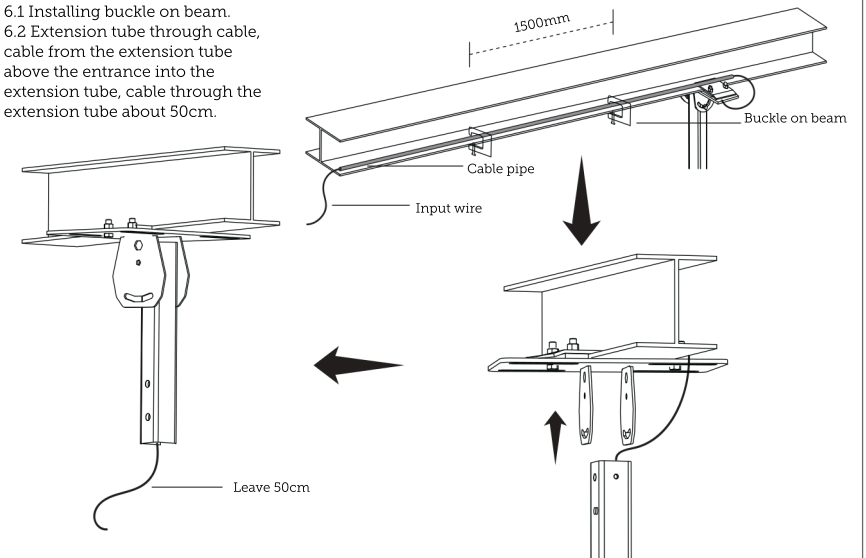

Fan Installation Guidelines

Step 7 Install Wire Rope

Wrap the wire rope around the beam, through the top plate ring hug. Set aside wire rope as a backup, use the lock buckles to connect the two ends of the wire rope, the lock buckle is two M6X5, and manual pre-tightening to prevent loose fall, use a 10mm sleeve to tighten the lock buckle screws.

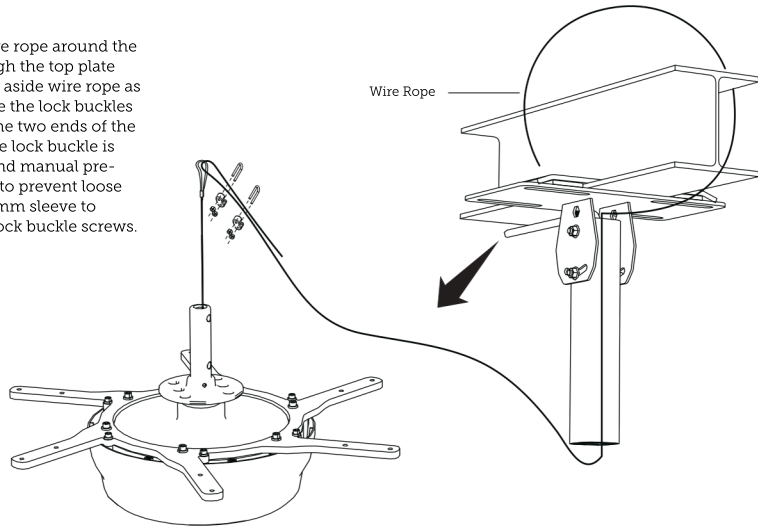

Step 8 Install the Motor

Connect the cable, connect the safety rope, align the upper end of the motor with the hole at the bottom of the extension tube, and install the motor to the extension tube with M10*16mm screws. Tighten the screws with a 7mm Allen wrench.



Adjust the wires in the extension tube and the wires of the motor in the same direction. When installing the motor, two people work together to lift the motor to prevent the motor from sliding sideways. One person wears the screws and wears protective equipment when tightening the screws to prevent tools from slipping touching the motor cover and hurting your hands.

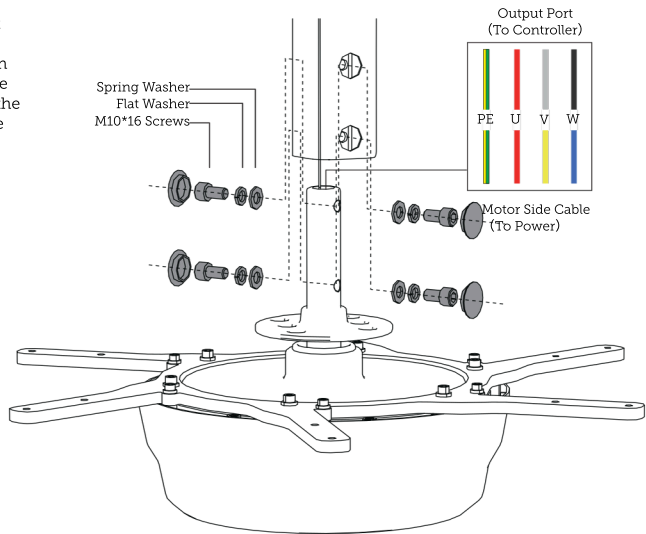

Fan Installation Guidelines

Step 9 Install Turnbuckle

Install the turnbuckle, fasten the turnbuckle steel wire lock, use a 14mm wrench to tighten the connecting ring nut, use a quick wrench and an 8mm sleeve, hold the lock buckle with one hand, and hold a tool in the other to tighten the lock buckle.

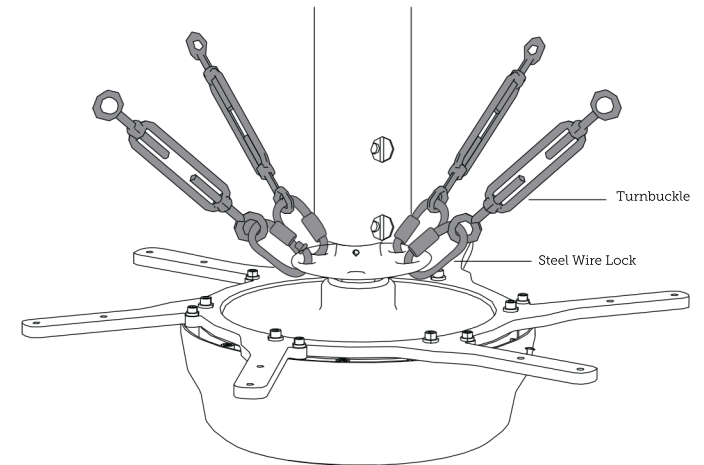

Step 10 Steel wire plate

Adjust the position of the steel wire plate and tighten it.

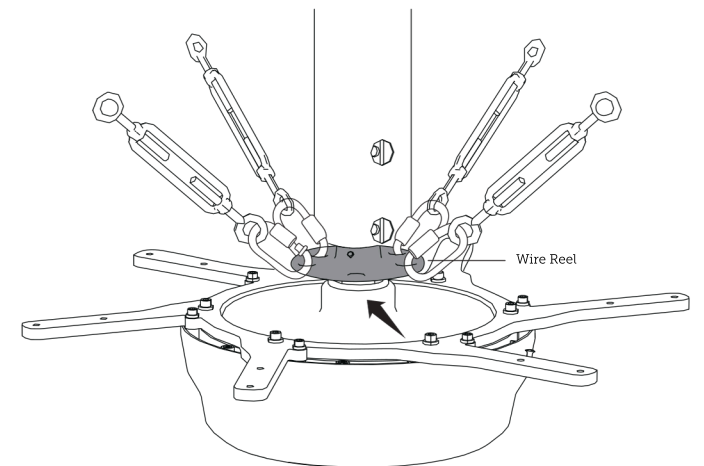

Fan Installation Guidelines

Step11 Pull the Wire Rope

At the pulling point, the wire rope will be passed through the hole and then manually fixed and pre-tightened using the lock buckle. Finally, tighten the lock buckle with quick wrench and 8mm sleeve.

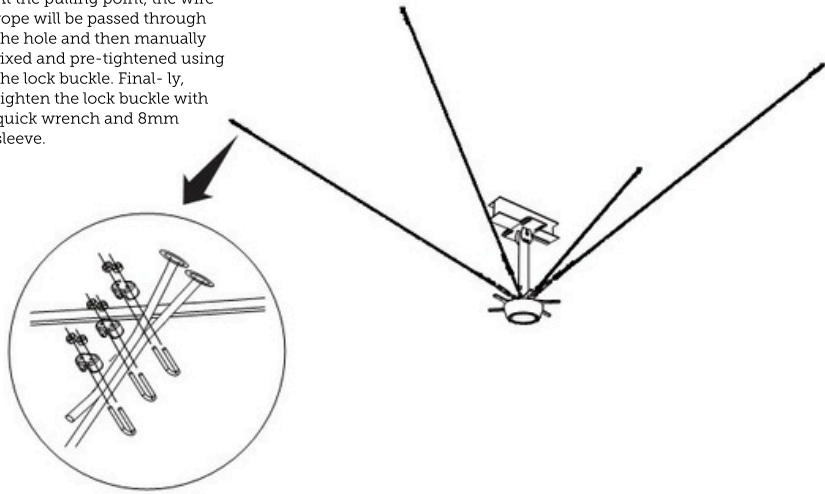

Step12 Wire Rope Connecting the Motor

Pull the other end of the wire rope to the turnbuckle end of the motor. After confirming the length (the end of the rope just touches the lower end of the extension tube), cut the wire rope, then pass it through the turnbuckle, tighten the wire rope, and use the lock buckle to manually fix the tight. Use the quick wrench and the 8mm sleeve to tighten the lock buckle, and repeat the above steps to pull all 4 wire ropes.

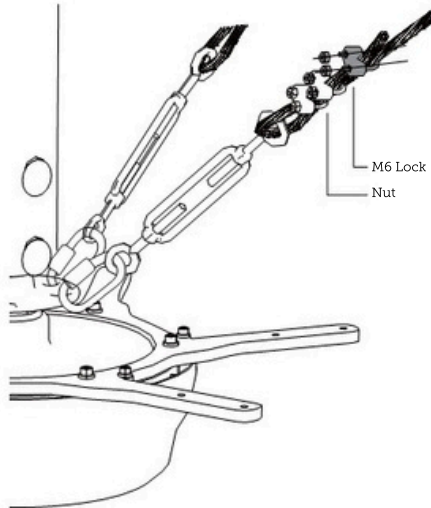

Fan Installation Guidelines

Step13 Adjust the Motor to a Balanced Position

Put the level ruler on the motor, measure the balance of the wire rope diagonally, adjust the flange and wire rope tightness diagonally according to the balance, use the quick wrench to lock the lock buckle, the wire tightness to flat tug the wire rope will not shake shall prevail, use the level ruler for many times to measure the four corners to ensure the horizontal balance.

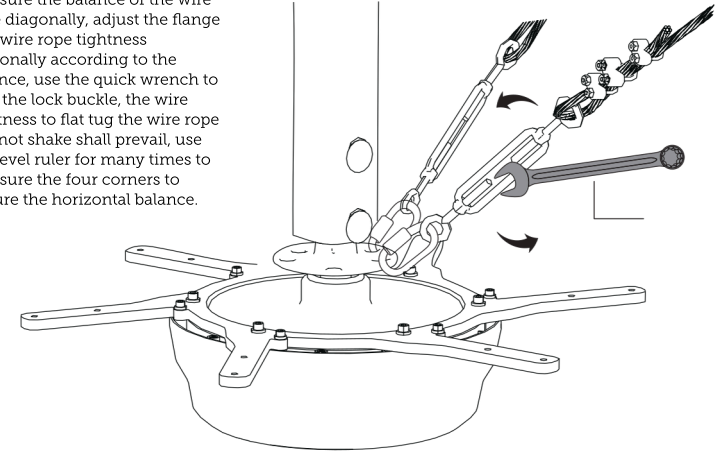

Step14 Install the Fan Blades

Install the fan blades diagonally to keep the center of gravity balanced. Insert the fan blades into the integrated fan blade connector of the motor, pre-tighten the screws by hand, and then tighten the 12 M8*20 screws with a 7mm Allen wrench. Repeat the above steps to install the 6 fan blades.

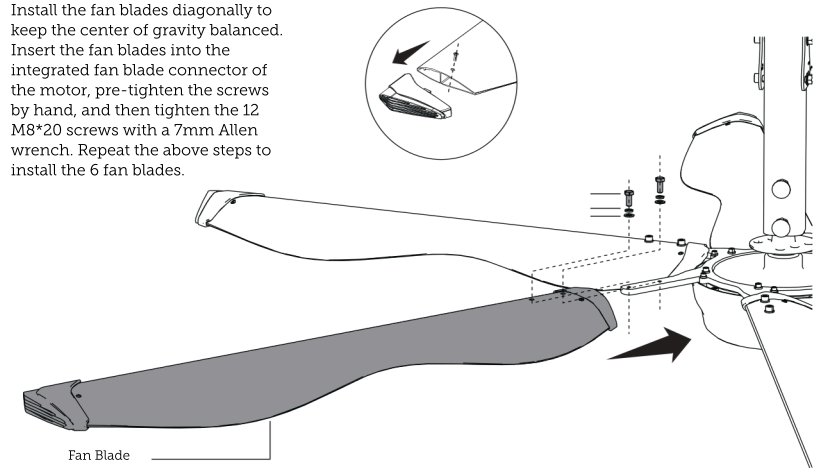

Fan Installation Guidelines

Step15 Install the Logo Cover

When installing the logo cover, fit the logo cover onto the chassis, align it with the screw hole, and rotate it clockwise to confirm that the logo cover is stuck and not loose.

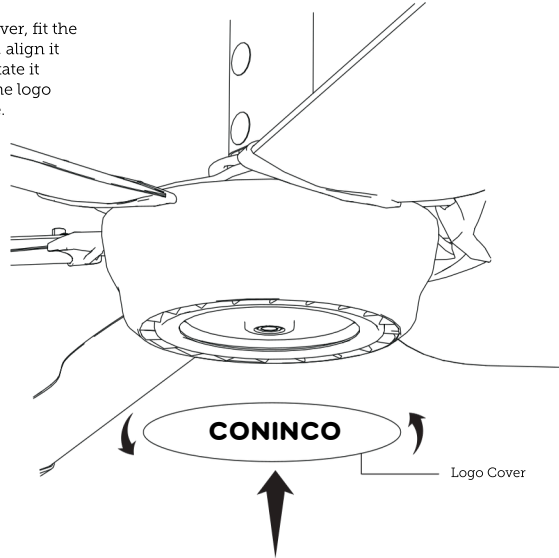

Step16 Controller backplate Installation

Place backplate of Standard Controller at 1.2-1.4m high (specific height depends on customer requirements and on-site conditions). Use a level ruler to adjust the backplate's horizontal position and mark the positions of four mounting holes.

Use a 4mm pistol drill to make holes at the marked positions. Insert expansion tubes. Place the backplate with a raised hook on top side. Use a cross screw-driver to screw in ST4.8*20 self-tapping screws into the expansion tubes to fix the backplate.

Place the level ruler at the bottom of the backplate to double check the backplate's horizontal position after it has been fixed.

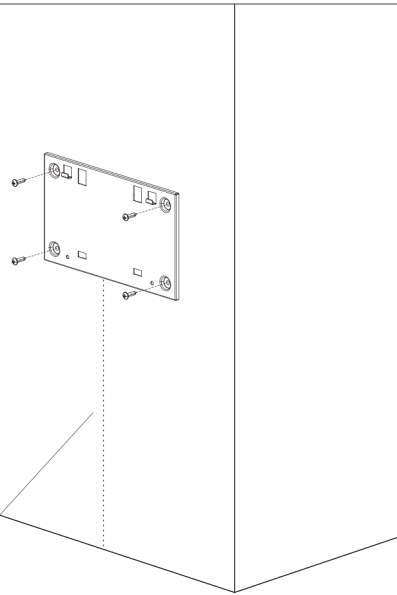

Recommended install height: 1.2-1.4m

Fan Installation Guidelines

Step17 Standard Controller installation

Position the upper end of controller 1cm above the backplate and gradually get closer to backplate. Ensure it is aligned both horizontally and vertically.

The lower end of the controller's backplate clip will press against the backplate. Press the upper end of the controller to fit it into the top portion of the backplate, then move the controller downwards so that the lower clip slides into the backplate hole. Make multiple adjustments to complete the controller installation.

Gently pull on the controller to check if it is firmly installed.

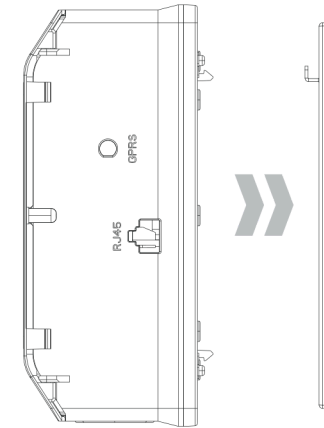

Step18 Standard Controller - Input and Output Cable Wiring

- Use a flathead screwdriver to gently pry the recessed area of the panel to open the cover.
- Slide the output cable into the metal hose (cut to the appropriate length). Put one end of the metal hose into the controller's output terminal and secured, fixing the metal hose.
- Pull the output cable out of the metal hose and insert it into the wiring compartment. Use wire strippers to strip insulation cover of output cable and then strip 1cm of insulation cover of 4 inner wires.
- Connect the yellow-green, red, grey, and black inner wires with the corresponding terminal (sPE/U/V/W) in the wiring compartment and tighten them.
- Repeat Step 2 to secure the input cable's metal hose.
- Pull the input cable out of the metal hose and insert it into the wiring compartment. Use wire strippers to strip insulation cover of input cable and then strip 1cm of insulation cover of 3 inner wires.
- Connect the yellow-green, red, and grey wires to the corresponding terminals (PE/L/N) in the wiring compartment and tighten them.
- Gently pull the seven inner wires to check if the connections are secure. Gently press and close the wiring compartment cover.

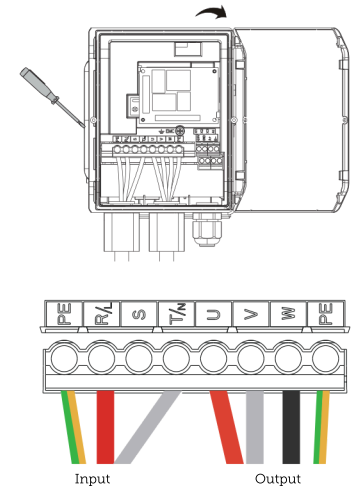

Fan Installation Guidelines

Step19 Check and Test Running

After the main power supply is powered on, the fan control cabinet power is powered on, and the fan starts running at a low frequency, gradually increasing the fan operating frequency until the highest value. Check whether the fan is running normally and whether there is any abnormal noise. If any problem is found, stop the fan immediately.

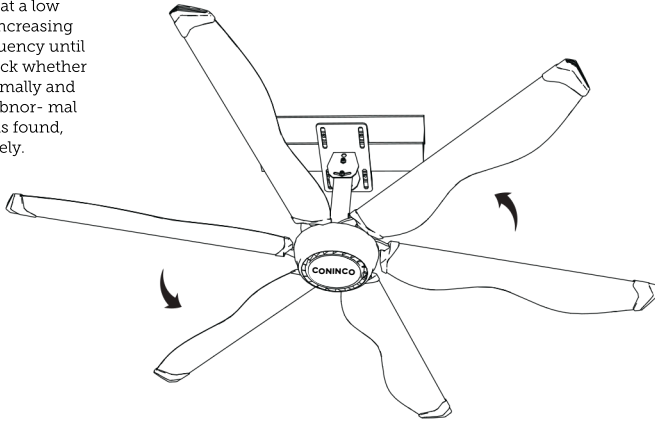

Tips Functional introduction of CONINCO Standard controller

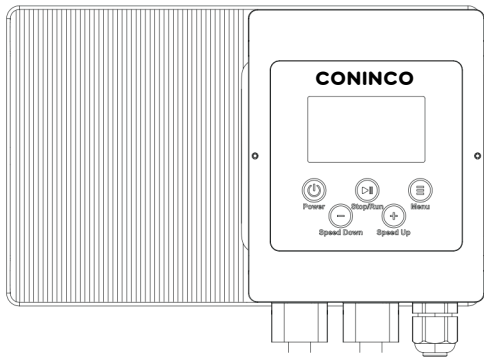

- Power Button: Hold down for 2S to turn on/off the controller. Turn off the fan when fan stopped.
- STOP/RUN: Press to run or stop fan operation.
- Speed Up/Down
- Menu: Press to enter Engineering Interface.

Error Code Description

Error Code	Failure Description	Failure Type
E.SC1 (1)	System failure when acceleration	Failure
E.SC2 (2)	System failure when deceleration	Failure
E.SC3 (3)	System failure during constant speed	Failure
E.SC4 (4)	System downtime failure	Failure
E.OC1 (5)	Overcurrent during acceleration	Failure
E.OC2 (6)	Overcurrent during deceleration	Failure
E.OC3 (7)	Overcurrent at constant speed	Failure
E.OU1 (9)	Overvoltage during acceleration	Failure
E.OU2 (10)	Overvoltage during deceleration	Failure
E.OU3 (11)	Overvoltage at constant speed	Failure
E.LU (13)	Undervoltage during operation	Failure
E.OL1 (14)	The motor is overloaded	Failure
E.OL2 (15)	Inverter 1 is overloaded	Failure
E.OL3 (16)	Inverter 2 is overloaded	Failure
E.OL4 (17)	Inverter 3 is overloaded	Failure
E.ILF (18)	Phase false in input	Failure
E.OLF (19)	Phase false in output	Failure
E.OLF1 (20)	U Phase false	Failure
E.OLF2 (21)	V Phase false	Failure
E.OLF3 (22)	W Phase false	Failure
E.OH1 (30)	The rectifier module is overheated	Failure
E.OH2 (31)	IGBT module is overheated	Failure
E.OH3 (32)	The motor is overheated	Failure
E.EF (33)	External faults	Failure
E.CE (34)	Modbus communication failures	Failure
E.HAL1 (35)	U phase zero drift large	Failure
E.HAL2 (36)	V phase zero drift large	Failure
E.HAL (37)	Sum of 3-phase current vectors ≠0	Failure
E.HAL3 (38)	W phase zero drift large	Failure
E.SGxx (40)	Ground-wire short-circuit	Failure
E.FSG (41)	Fan short-circuit	Failure
E.PID (42)	PID line disconnected	Failure
E.COP (43)	Parameter copy failure	Failure
E.PG1 (44)	Incorrect PG parameter setting	Failure
E.PG2 (44)	Encoder Z pulse failure	Failure
E.PG3 (44)	Resolver verification error	Failure
E.PG4 (44)	Resolver breakage	Failure
E.PG5 (44)	ABZ encoder disconnection	Failure
E.PG6 (44)	Main encoder disconnection	Failure
E.PG7 (44)	Main encoder Z pulse error failure	Failure
E.PG8 (44)	Encoder Z pulse logic failure	Failure
E.PG9 (44)	Main encoder Z pulse logic failure	Failure
E.PG10 (44)	Encoder Z pulse disconnection	Failure
E.BRU (50)	Brake module failure	Failure
E.TExx (52)	Parameter self-learning failure(Motor)	Failure
E.IAE1 (71)	Motor angle learning failure 1	Failure
E.IAE2 (72)	Motor angle learning failure 2	Failure
E.IAE3 (73)	Motor angle learning failure 3	Failure
E.PST1 (74)	PMSM Step-out 1	Failure
E.PST2 (75)	PMSM Step-out 2	Failure
E.PST3 (76)	PMSM Step-out 3	Failure
E.DEF (77)	The speed deviation is too large	Failure
E.SPD (78)	Abnormal frequency failure	Failure

Error Code	Failure Description	Failure Type
E.LD1 (79)	Load protection 1	Failure
E.LD2 (80)	Load protection 2	Failure
E.CPU (81)	CPU Timeout failures	Failure
E.LOC (85)	IC failure	Failure
E.EEP (86)	Parameter saving Failure	Failure
E.PLL (87)	Phase-locked loop Failure	Failure
E.BUS1 (91)	Expansion card A disconnection	Failure
E.BUS2 (92)	Expansion card B disconnection	Failure
E.BUS3 (93)	CAN Expansion card failure	Failure
E.BUS4 (94)	Other expansion card failure	Failure
E.BUS5 (95)	Other expansion card failure	Failure
E.BUS6 (96)	Other expansion card disconnection	Failure
E.CP1 (97)	The monitor output failure	Failure
E.CP2 (98)	The monitor output failure	Failure
E.DAT (99)	Parameter setting failure	Failure
E.FA1 (110)	Externally extended reservations 1	Failure
E.FA2 (111)	Externally extended reservations 2	Failure
E.FA3 (112)	Externally extended reservations 3	Failure
E.FA4 (113)	Externally extended reservations 4	Failure
E.FA5 (114)	Externally extended reservations 5	Failure
E.FA6 (115)	Externally extended reservations 6	Failure
E.FA7 (116)	Externally extended reservations 7	Failure
E.FA8 (117)	Externally extended reservations 8	Failure
A.LU1 (128)	Shutdown undervoltage	Warning
A.OU (129)	Shutdown overpressure	Warning
A.ILF (130)	Phase false in input	Warning
A.PID (131)	PID line disconnected	Warning
A.EEP (132)	Parameter saving warnings	Warning
A.DEF (133)	The speed deviation is too large	Warning
A.SPD (134)	Abnormal frequency warning	Warning
A.GP51 (135)	GPS device locking	Warning
A.GP52 (136)	GPS line disconnected	Warning
A.CE (137)	External Warning	Warning
A.LD1 (138)	Load protection 1	Warning
A.LD2 (139)	Load protection 2	Warning
A.BUS (140)	Expansion card disconnection warning	Warning
A.OH1 (141)	Module overheat warning	Warning
A.OH3 (142)	Motor overheat warning	Warning
A.RUN1 (143)	Conflicting directives	Warning
A.RUN2 (158)	Manual terminal start-up protection	Warning
A.RUN3 (159)	Terminal start-up protection	Warning
A.PA2 (144)	External keyboard disconnection warning	Warning
A.COP (145)	Parameter Copy warning	Warning
A.CP1 (146)	The monitor output 1	Warning
A.CP2 (147)	The monitor output 2	Warning
A.FA1 (150)	Externally extended reservations 1	Warning
A.FA2 (151)	Externally extended reservations 2	Warning
A.FA3 (152)	Externally extended reservations 3	Warning
A.FA4 (153)	Externally extended reservations 4	Warning
A.FA5 (154)	Externally extended reservations 5	Warning
A.FA6 (155)	Externally extended reservations 6	Warning

Safety Instructions

Prohibitions



- Do not bend or deform the fan blades during installation, adjustment, or cleaning. Doing so may result in damage to the fan or impair its performance.
- Ensure that the fan's input voltage matches the supply voltage before switching on the power.
- Do not perform any maintenance or repairs on the fan while the power is on to prevent the risk of electric shock.
- Unauthorized modifications to the fan's structure or mounting position are strictly prohibited.
- Do not open the electrical control cabinet while it is energized, as this may lead to electric shock hazards.
- Operating damaged equipment is strictly prohibited. Continued use may result in severe equipment failure or personal injury.
- Do not alter the configuration or parameters of the controller without authorization. Improper modifications may cause equipment malfunction or pose a safety risk.
- The fan controller contains high-voltage storage capacitors. When servicing the regulator, wait at least 3 minutes after power is disconnected to allow capacitors to discharge to a safe voltage level.
Note: The display turning off is not an indication that it is safe to proceed.
- Do not operate the fan in environments where the designated safety clearance is insufficient.
- Installation and wiring must be performed by personnel who have been certified according to our technical qualification standards.

Cautions



- Circuit layout and wiring must be conducted exclusively by professionally qualified technicians authorized by CONINCO.
- Only use parts and accessories specified or approved by CONINCO.
- Do not disconnect the power supply while the fan is operating. Power should only be turned off once the fan has come to a complete stop to prevent potential damage.
- After completing wiring, ensure that conductors are properly separated: the equipment grounding conductor must be placed on one side of the outlet box, and the grounded (neutral) conductor on the other side.
- Do not switch to the reset mode while the fan is running in forward (clockwise) rotation. Doing so may result in mechanical failure.

Troubleshooting

Common Causes of Failures

- The on-site power supply is invalid or not connected properly.
- After turning on the main switch, press and hold the "ON/OFF" button for more than 2 seconds, then press the "RUN/STOP" button. If the fan still fails to operate normally, please contact us immediately.

⚠ Non-professionals must not disassemble the controller!

For any repair or adjustment work, please contact us so that it can be handled by qualified technicians or engineers.

If any abnormal operation or unusual noise is detected, immediately stop the fan, disconnect the power supply, and contact us as soon as possible.

Note: Any damage caused by improper use will void the entire warranty.

CONINCO is not responsible for any personal injury or equipment damage resulting from failure to follow the instructions in this manual.

Importance of After-Sales Service

High-quality after-sales service plays a crucial role in ensuring the long-term and stable operation of fans.

To this end, CONINCO is committed to providing customers with premium products and comprehensive after-sales support.

We have established a global sales and service network to deliver timely, considerate, efficient, and all-around after-sales assistance—ensuring a worry-free experience for all our customers.

Technical Support

During the installation, commissioning, and operation of the fan, CONINCO will provide technical support in the following areas:

Product information, usage instructions, maintenance guidance, and product certifications. You can obtain technical support through the following channels:

- Visit website: www.conincofans.com for the latest technical documents
- Contact our after-sales support team: support@conincofans.com
- Reach out to your designated sales representative

Application Environment

Environment	Requirements
Installation site	Indoor
Operating Temperature	-15°C to +55°C Do not operate the fan in environments with rapid temperature fluctuations.
Humidity	< 95%RH
Altitude Range	< 1000m
Others	The fan should be installed in an environment that meets the following conditions: <ul style="list-style-type: none"> • No presence of corrosive, flammable, or explosive gases. • Free from airborne metal particles, oil mist, excessive humidity, or other foreign substances. • Minimal exposure to salt spray or corrosive agents.

Warranty & Maintenance

The product is designed to be maintenance-free under standard operating conditions. However, to ensure long-term and stable performance—especially when used in harsh environments—regular maintenance is still recommended. Before performing any maintenance on the fan or controller, always ensure the fan is completely stopped and the controller's power supply is disconnected to ensure personnel safety.

Recommended Maintenance Schedule and Tasks:

During trial operation:
Check for any abnormal noise or vibration during fan operation.

Every 2,500 operating hours:
Clean the controller and fan blades.

Every 5,000 operating hours:

- Inspect all fasteners for signs of loosening.
- Check all cables for any signs of damage.

If noticeable noise or vibration occurs during fan operation, it may indicate mechanical component failure. In such cases, immediately disconnect the power supply and perform a thorough inspection.

Product Warranty Policy

Warranty Period: one (1) year from the date of delivery of the complete unit.

Warranty Claims:





If any product failure occurs within the warranty period, do not attempt to disassemble or repair the product yourself. Please contact your local CONINCO representative as soon as possible. However, CONINCO reserves the right to charge for repair or service under the following circumstances:

- Failure caused by improper installation, handling, or operation;
- Failure resulting from unauthorized modification or alteration of CONINCO products;
- Damage due to natural disasters, fire, or other force majeure events;
- Failure occurring after the expiration of the warranty period;
- Any other malfunction or damage not attributable to CONINCO.

Quality Assurance:

All CONINCO products are manufactured under a strict quality management system. Each unit undergoes comprehensive testing and inspection prior to delivery to ensure reliability and performance.

Control Cabinet User Manual

Display Area	Function Definitions
	Power Button: Press and hold for more than 2 seconds to power the fan ON or OFF.
	Menu Button: <ul style="list-style-type: none"> In User Interface Mode: No function (press and hold for 2 seconds to enter Engineer Interface for parameter display). In Engineer Interface Mode: Short press (under 2 seconds) to return to User Interface.
	Start/Stop Button: In User Interface Mode: Short press (under 2 seconds) to start or stop the fan. In Engineer Interface Mode: <ul style="list-style-type: none"> Short press (under 2 seconds) to toggle monitored variables (e.g., current, voltage). Press and hold for more than 2 seconds to exit Engineer Interface and return to User Interface.
	Speed Adjustment Buttons: Used to increase or decrease the fan speed level.







Safety Instructions

Before operating the fan, please read the manual carefully. Ensure the operating area is free of obstacles and that there is sufficient clearance for safe fan operation.

Warning:

Always disconnect power before performing any electrical or fan maintenance. All maintenance work must be carried out by authorized professionals to avoid risk of electric shock.

Control Cabinet User Manual

Display Area	Function Definitions
	Display of speed level and relevant icons
ON OFF	Operating status indicators
	Fault warning icons
	Engineer mode indicator
	Parameter readings and unit symbols

RUN

- Ensure there are no obstacles or potential hazards in the fan's operating area.
- Confirm that the input power is correct and meets product specifications.
- After powering on the unit, use the "Increase" and "Decrease" buttons to adjust to the optimal operating speed.

STOP

- To stop the fan, press the "Run/Stop" button.
- Do not cut power directly while the fan is in normal operation.

