



LuxAir Series HVLS Fans

Fan Diameter: 2000–4200 mm

Innovating Air Movement for a Sustainable Future

The **LuxAir series** HVLS (High-Volume Low-Speed) fans are high-performance products specifically designed to optimize air circulation in large spaces, enhance comfort, and improve energy efficiency. Their innovative airflow design provides gentle yet efficient air coverage, helping to significantly improve the environment, reduce energy consumption, and making them especially suitable for places that require temperature stability and air quality control.

Key benefits for customers include:

- **Enhanced Airflow Efficiency:** The LuxAir series HVLS fans are designed to optimize air circulation in large spaces, ensuring even air distribution and improving overall ventilation, helping maintain a comfortable environment in expansive areas.
- **Energy Savings:** With advanced motor technology and an efficient fan design, these fans significantly reduce energy consumption, lowering electricity bills and operational costs, especially in large facilities.
- **Improved Comfort and Air Quality:** The fans enhance airflow, reduce temperature stratification, and eliminate hot or cold spots, improving overall air quality and thermal comfort, particularly effective in high-ceiling environments.
- **Sustainable and Eco-Friendly:** The fans reduce their carbon footprint and contributing to sustainability goals.

LuxAir Series HVLS Fans

Product Applications

LuxAir series HVLS (High-Volume Low-Speed) fans are high-performance products specifically designed to optimize air circulation in large spaces, enhance comfort, and improve energy efficiency. Their innovative airflow design provides gentle yet efficient air coverage, helping to significantly improve the environment, reduce energy consumption, and making them especially suitable for places that require temperature stability and air quality control.

By choosing LuxAir products, customers gain a sustainable, cost-effective, and high-performance solution for airflow and comfort needs.

Application Scenarios:

- **Commercial Spaces:** Large shopping malls, supermarkets, exhibition halls, used to enhance air circulation and optimize customer experience.
- **Public Facilities:** Sports venues, airport terminals, schools, and other spacious areas, used to maintain fresh air and temperature balance.
- **Agriculture and Animal Husbandry:** Agricultural greenhouses, farms, used to improve air quality and reduce mold and pest problems.
- **Fitness and Leisure:** Gyms, yoga studios, and other indoor sports spaces, used to provide a cool and comfortable exercise environment.
- **Industrial Sites:** Factories, logistics warehouses, used for expelling heat, controlling humidity, and improving worker comfort.

LuxAir series fans offer excellent airflow coverage, low energy consumption, quiet and efficient operation, and intelligent control, providing a comprehensive air optimization solution for industrial, commercial, and public spaces. It is one of the top-performing HVLS fan products available in the market today.



CONINCO Fans
**Powering Comfort,
Elevating Performance**

**DISCOVER MORE ABOUT
CONINCO HVLS Fans**

Learn more at www.conincofans.com
or call **US** for a free custom quote

LuxAir Series HVLS Fans

Key Features



Advanced PMSM Technology

CONINCO Fans equipped with PMSM (Permanent Magnet Synchronous Motor) technology deliver exceptional energy efficiency, stable performance, and ultra-quiet operation. These motors provide precise control and consistent airflow, making them ideal for large spaces. With a compact, lightweight design and maintenance-free requirements, PMSM motors enhance reliability and reduce operational costs, offering a sustainable and high-performance solution.

Durability and Stability

The fan blades are made of aerospace-grade aluminum alloy, offering exceptional corrosion resistance and mechanical strength, making them suitable for high-humidity and corrosive environments. • With a high protection rating, the fan can operate stably in various complex environments, including outdoor semi-open areas.

High Safety

Equipped with multiple safety protection features, including anti-detachment design, safety steel wire reinforcement, overload protection, and overheating protection, ensuring reliable and safe operation. • The fan is certified by multiple international standards, meeting global safety and environmental requirements



Large Airflow Coverage

Featuring an optimized aerodynamic design, the fan blades are wide and efficient, providing large-area air coverage to effectively solve air circulation problems in large spaces. • Even airflow distribution reduces air stratification, ensuring consistent airflow across all areas.

Low Speed, High Efficiency

The low-speed design generates large airflow at low power, significantly reducing energy consumption with low power per unit, enabling energy-efficient operation. • Even at very low speeds, the fan can effectively move large volumes of air, resulting in a perceived temperature drop of 5-8°C, improving indoor comfort

Energy Saving and Environmentally Friendly

High-efficiency motor (PMSM permanent magnet synchronous motor) with an efficiency greater than 90%, reducing energy loss by 30%-50% compared to traditional motors. • When used with air conditioning systems, it can reduce cooling or heating energy consumption by 20%-30%.

Silent Operation

Low noise levels, utilizing high-precision bearings and vibration-damping technology, ensuring quiet and stable operation even during extended use, ideal for environments where noise control is essential.

Intelligent Control

Supports multiple control modes, allowing users to flexibly adjust fan speed and operation time according to specific needs.

LuxAir Series HVLS Fans Technical Parameters

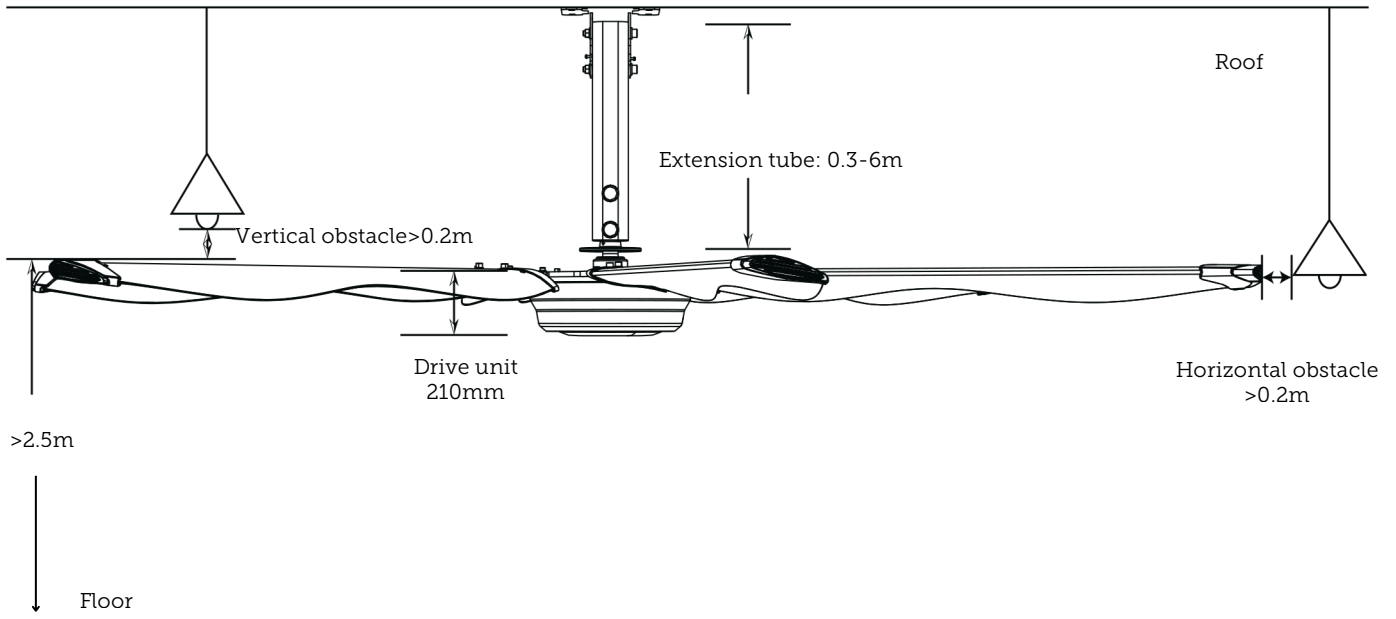

Fan	Diameter	Air volume, m ³ /min	Weight	Max speed	Input power	Full load current
LA6-42	14ft (4.2m)	7550	115 lb (52kg)	72RPM	0.35kw	1.5A
LA6-36	12ft (3.6m)	6560	106 lb (48kg)	95RPM	0.33kw	1.3A
LA6-30	10ft (3.0m)	5250	97 lb (44kg)	110RPM	0.30kw	1.1A
LA6-25	8ft (2.5m)	4550	90 lb (41kg)	130RPM	0.26kw	0.8A
LA6-20	6.5ft (2.0m)	3900	84 lb (38kg)	150RPM	0.14kw	0.4A

Installation Requirements:

- Building Structure: H-beams, I-beams, steel-concrete square beams, spherical column types, and other structures.
- The minimum safe distance between the fan blades and obstacles is 0.2m.

Others:

- Weight: Above weight does not include control cabinet, extension rods, top connection components, etc.
- Fan Diameter: The diameters listed above are standard product sizes; other specifications can be customized.
- Blade Color: The standard color is white; other colors are customizable.
- Input Power: Single-phase 220V \pm 10%.
- Alternative Voltage Specifications Available Upon Request



White

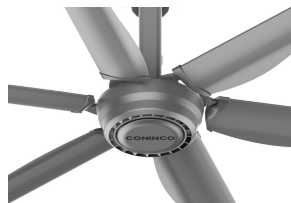

Silver



Black

CONINCO Fans

Email: sales@conincofans.com
 Website: www.conincofans.com
 Tel: +65 69587868



All rights reserved. | Version 2025.04
 Specifications subject to change without notice.